

Digitale Medien

Übung

Heute

- Hexadezimalsystem
- Little-Endian vs. Big-Endian
- WAVE-Format

Hexeditor

Zeigt einzelne Bytes einer Datei an

z.B. Linux:

khxedit

Windows:

fhred (frhed.sourceforge.net/)

Mac OS X:

HexEdit (<http://hexedit.sourceforge.net/>)

The screenshot shows the fhred hex editor interface. The title bar indicates the file path: [C:\Documents and Settings\dominikus\Desktop\ue6\secret_message.wav] - fhred. The menu bar includes File, Disk, Edit, View, Options, Registry, Bookmarks, Misc, and Help. The main window displays a hex dump of the file's contents, with the first few lines showing the RIFF header for a WAV file. The hex dump is organized into columns of 16 bytes each, with corresponding ASCII characters shown to the right. The status bar at the bottom indicates 'Offset 3=0x3 Bits=01000110', 'Unsigned: B:70, W:9286, L:256386118', 'ANSI / OVR / L', and 'Size: 1001516'.

```

000000 52 49 46 46 24 48 0f 00 57 41 56 45 66 6d 74 20 10 00 00 00 01 00 02 00 44 ac RIFF$H.WAVEfmt . . . . D-
00001a 00 00 10 b1 02 00 04 00 10 00 64 61 74 61 00 48 0f 00 fe ff 02 00 00 00 fe ff . . . . data.H . . . . by
000034 04 00 fb ff 04 00 fe ff 01 00 00 00 ff ff 02 00 fd ff 03 00 ff ff fe ff 04 00 . . . . by . . . . yy . . . . yy . . . . by
00004e fb ff 05 00 fc ff 03 00 fd ff 03 00 fe ff 01 00 00 00 ff ff 01 00 00 00 ff ff . . . . by . . . . yy . . . . by . . . . yy . . . . yy
000068 02 00 fe ff 00 00 02 00 fd ff 03 00 fe ff 01 00 00 00 ff ff 02 00 fd ff 03 00 . . . . by . . . . yy . . . . by . . . . yy . . . . yy
000082 fe ff 01 00 00 00 00 00 fd ff 03 00 00 00 00 00 00 00 00 00 01 00 fe ff 03 00 . . . . by . . . . yy . . . . by . . . . yy . . . . yy
00009c fd ff 02 00 fe ff 03 00 fd ff 03 00 fe ff 00 00 01 00 ff ff 00 00 01 00 ff ff . . . . by . . . . yy . . . . by . . . . yy . . . . yy
0000b6 00 00 01 00 fe ff 02 00 ff ff 00 00 01 00 fe ff 03 00 fd ff 02 00 00 00 fe ff . . . . by . . . . yy . . . . by . . . . yy . . . . by
0000d0 03 00 fd ff 03 00 fe ff 00 00 01 00 ff 02 00 fe ff 01 00 ff 01 00 ff 01 00 00 . . . . yy . . . . yy . . . . by . . . . yy . . . . by
0000ea 00 00 ff ff 02 00 fd ff 03 00 fd ff 02 00 ff ff 00 00 01 00 fe ff 02 00 ff ff . . . . yy . . . . yy . . . . yy . . . . by . . . . yy
000104 00 00 00 00 01 00 ff ff 01 00 ff ff 01 00 ff ff 01 00 ff ff 01 00 ff ff 00 . . . . yy . . . . yy . . . . yy . . . . yy . . . . yy
00011e 01 00 fe ff 03 00 fd ff 03 00 fd ff 02 00 ff ff 00 00 01 00 ff ff 01 00 ff ff . . . . by . . . . yy . . . . yy . . . . yy . . . . yy
000138 01 00 ff ff 02 00 fd ff 04 00 fb ff 06 00 fa ff 05 00 fd ff 00 00 03 00 fc ff . . . . yy . . . . yy . . . . yy . . . . yy . . . . yy
000152 03 00 ff ff ff ff 02 00 fe ff 02 00 fe ff 02 00 fe ff 02 00 ff ff ff ff 02 00 . . . . yyy . . . . by . . . . by . . . . yyy . . . .
00016c fe ff 01 00 00 00 00 00 00 00 00 00 00 00 00 00 00 00 01 00 ff ff 01 00 . . . . by . . . . yy . . . . yy . . . . yy . . . . yy
000186 fe ff 02 00 ff ff 00 00 01 00 00 00 fe ff 03 00 fd ff 02 00 ff ff 01 00 ff ff . . . . by . . . . yy . . . . by . . . . yy . . . . yy
0001a0 01 00 ff ff 00 00 02 00 fd ff 03 00 fe ff 01 00 00 00 00 00 ff ff 02 00 fe ff . . . . yy . . . . yy . . . . by . . . . yy . . . . by
0001ba 01 00 00 00 00 00 ff ff 01 00 00 00 ff ff 02 00 fe ff 01 00 ff ff 01 00 00 00 . . . . yy . . . . yy . . . . by . . . . yy . . . . by
0001d4 00 00 00 00 ff ff 00 00 01 00 00 00 ff ff 02 00 fd ff 02 00 00 00 00 fe ff 03 00 . . . . yy . . . . yy . . . . yy . . . . by . . . . by
0001ee fe ff 00 00 01 00 ff ff 01 00 fe ff 02 00 fe ff 03 00 fd ff 01 00 00 00 00 00 . . . . by . . . . yy . . . . by . . . . yy . . . . yy
000208 00 00 00 00 00 00 00 00 01 00 fe ff 02 00 ff ff 00 00 01 00 ff ff 00 00 01 00 . . . . by . . . . yy . . . . by . . . . yy . . . . yy
000222 fe ff 03 00 fc ff 04 00 fc ff 03 00 ff ff 00 00 ff ff 02 00 fe ff 01 00 01 00 . . . . by . . . . yy . . . . yy . . . . yy . . . . by
00023c fe ff 03 00 fc ff 03 00 ff ff 00 00 01 00 fe ff 02 00 fe ff 03 00 fc ff 04 00 . . . . by . . . . yy . . . . by . . . . by . . . . yy
000256 fd ff 02 00 ff ff 00 00 01 00 fe ff 03 00 fd ff 02 00 ff ff 00 00 00 00 01 00 . . . . yy . . . . yy . . . . by . . . . yy . . . . yy
000270 fe ff 02 00 ff ff ff ff 02 00 fe ff 00 00 00 00 00 00 00 00 01 00 fe ff 02 00 . . . . by . . . . yyy . . . . yy . . . . by . . . .
00028a fe ff 02 00 fe ff 01 00 01 00 fe ff 01 00 00 00 00 00 00 00 01 00 fd ff 03 00 . . . . by . . . . by . . . . by . . . . yy . . . .
0002a4 ff ff ff ff 02 00 fe ff 00 00 02 00 fe ff 01 00 00 00 ff ff 01 00 00 00 ff ff . . . . yyy . . . . by . . . . by . . . . yy . . . . yy
0002be 02 00 fe ff 02 00 fe ff 02 00 fd ff 04 00 fd ff 02 00 ff ff 00 00 00 00 01 00 . . . . by . . . . by . . . . yy . . . . yy . . . . yy
0002d8 ff ff 00 00 01 00 ff ff 01 00 00 00 ff ff 01 00 ff ff 01 00 00 00 ff ff 01 00 . . . . yy . . . . yy . . . . yy . . . . yy . . . . yy
0002f2 ff ff 01 00 00 00 fe ff 03 00 fd ff 03 00 ff ff 01 00 00 00 ff ff 03 00 . . . . yy . . . . by . . . . yy . . . . yyy . . . . yy
00030c fc ff 04 00 fd ff 02 00 fe ff 01 00 01 00 ff ff 01 00 fe ff 01 00 01 00 ff ff . . . . yy . . . . by . . . . yy . . . . by . . . . yy
000326 01 00 fe ff 02 00 ff ff 00 00 02 00 fd ff 03 00 fc ff 04 00 fd ff 03 00 fe ff . . . . by . . . . yy . . . . yy . . . . yy . . . . by
000340 ff ff 03 00 fc ff 05 00 fb ff 03 00 ff ff 00 00 01 00 ff ff 00 00 01 00 fe ff . . . . yy . . . . yy . . . . yy . . . . yy . . . . by
00035a 03 00 fd ff 03 00 fe ff 00 00 02 00 fd ff 03 00 ff ff ff ff 02 00 fe ff 02 00 . . . . yy . . . . by . . . . yy . . . . yyy . . . . by . . . .
000374 fe ff 02 00 fe ff 02 00 ff ff ff ff 02 00 fd ff 03 00 ff ff ff ff 02 00 fe ff . . . . by . . . . by . . . . yyy . . . . yy . . . . yyy . . . . by
00038e 01 00 00 00 00 00 00 00 01 00 ff ff 00 00 00 00 00 00 01 00 ff ff 01 00 fe ff . . . . by . . . . yy . . . . yy . . . . yy . . . . by
0003a8 02 00 ff ff 01 00 ff ff 01 00 fe ff 02 00 ff ff 01 00 ff ff 01 00 fd ff 05 00 . . . . yy . . . . yy . . . . by . . . . yy . . . . yy
0003c2 fb ff 04 00 fe ff 00 00 01 00 ff ff 01 00 ff ff 01 00 ff ff 01 00 00 00 ff ff . . . . yy . . . . by . . . . yy . . . . yy . . . . yy
0003dc 01 00 00 00 00 00 00 00 00 00 ff ff 02 00 fe ff 03 00 fc ff 03 00 fe ff 01 00 . . . . yy . . . . yy . . . . by . . . . by . . . . yy
0003f6 01 00 ff ff ff ff 02 00 fd ff 04 00 fe ff 04 00 fe ff 02 00 fd ff 03 00 ff ff ff ff . . . . yyy . . . . yy . . . . by . . . . yy . . . . yyy
000410 02 00 fd ff 02 00 00 00 ff ff 01 00 00 00 fe ff 03 00 fd ff 03 00 fe ff 00 00 . . . . yy . . . . yy . . . . by . . . . by . . . . yy
00042a 02 00 fd ff 04 00 fb ff 04 00 fd ff 03 00 fe ff 01 00 fe ff 02 00 ff ff 00 00 . . . . yy . . . . yy . . . . by . . . . by . . . . yy
000444 01 00 fe ff 02 00 fe ff 02 00 fe ff 02 00 fe ff 02 00 fe ff 02 00 fe ff 01 00 . . . . by . . . . by . . . . by . . . . by . . . . by
00045e 01 00 fe ff 02 00 fe ff 02 00 fe ff 02 00 fe ff 02 00 fe ff 03 00 fc ff 04 00 . . . . by . . . . by . . . . by . . . . by . . . . yy
000478 fc ff 03 00 ff ff 00 00 00 00 00 00 00 00 00 00 00 00 00 00 00 00 00 00 . . . . yy . . . . yy . . . . yy . . . . yy
000492 00 00 00 00 00 00 ff ff 03 00 fc ff 04 00 fd ff 00 00 04 00 fa ff 07 00 f9 ff . . . . yy . . . . yy . . . . yy . . . . yy . . . . yy
0004ac 04 00 00 00 fe ff 03 00 fd ff 02 00 ff ff 01 00 00 00 03 00 fd ff 02 00 00 00 . . . . by . . . . yy . . . . by . . . . yy . . . .

```

Hexadezimal nach Dezimal

A4C₁₆ (0xA4C)

$$\mathbf{C} * 16^0 + \mathbf{4} * 16^1 + \mathbf{A} * 16^2 =$$

$$12 * 12 + 4 * 16 + 10 * 256 =$$

$$12 + 64 + 2560 =$$

2636₁₀

Google

"0xFFFF to decimal"

"XXXXXX to hex"

Hexadecimal	Binary	Decimal
0	0000	0
1	0001	1
2	0010	2
3	0011	3
4	0100	4
5	0101	5
6	0110	6
7	0111	7
8	1000	8
9	1001	9
A	1010	10
B	1011	11
C	1100	12
D	1101	13
E	1110	14
F	1111	15

[Hintergrund und Umrechnung](#)

Hexadezimal nach Dezimal

0xFF

0x7F

0x1C0

Google

"0xFFFF to decimal"

"XXXXXX to hex"

Hexadecimal	Binary	Decimal
0	0000	0
1	0001	1
2	0010	2
3	0011	3
4	0100	4
5	0101	5
6	0110	6
7	0111	7
8	1000	8
9	1001	9
A	1010	10
B	1011	11
C	1100	12
D	1101	13
E	1110	14
F	1111	15

[Hintergrund und Umrechnung](#)

Big-Endian versus Little-Endian

Byteweise Ausleserichtung:

Big-Endian: Höchster Wert zuerst

$$234 \Rightarrow 2 * 100 + 3 * 10 + 4 * 1$$

Little-Endian: Niedrigster Wert zuerst

$$234 \Rightarrow 2 * 1 + 3 * 10 + 4 * 100$$

Sprache:

24 = „twenty-four“ (Englisch – Big-Endian)

24 = „vierundzwanzig“ (Deutsch – Little-Endian)

Im Speicher:

0A 11 34 FF

Big-Endian: 0A 11 34 FF => 168 899 839

Little-Endian: FF 34 11 0A => 4 281 602 314

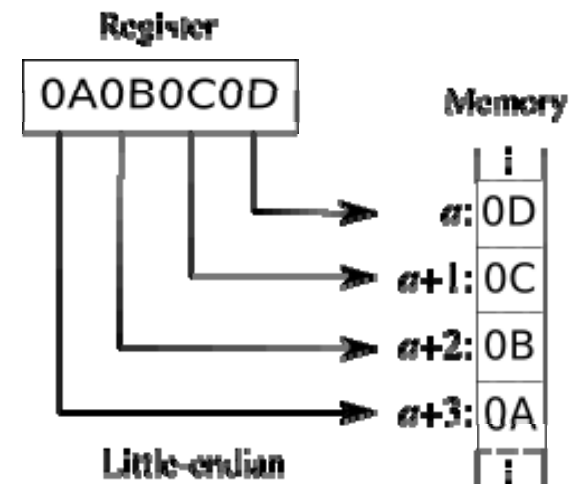
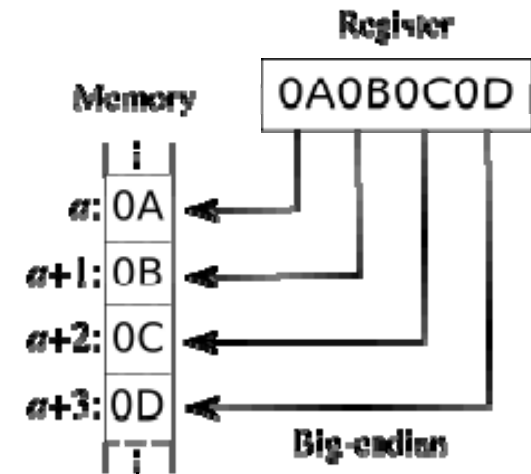

33 FA CC 00

Big-Endian: 0x33FACC00 => 872 074 240

Little-Endian: 0x00CCFA33 => 13 433 395

00 00 0F 11

Big-Endian: 0x00000F11 => 3 857

Little-Endian: 0x110F0000 => 286 195 712

The Canonical WAVE file format

WAVE

endian	File offset (bytes)	Field name	Field Size (bytes)	
big	0	ChunkID	4	The "RIFF" chunk descriptor
little	4	ChunkSize	4	
big	8	Format	4	
big	12	Subchunk1ID	4	The "fmt" sub-chunk describes the format of the sound information in the data sub-chunk
little	16	Subchunk1 Size	4	
little	20	Audio Format	2	
little	22	NumChannels	2	
little	24	SampleRate	4	
little	28	ByteRate	4	
little	32	BlockAlign	2	
little	34	BitsPerSample	2	
big	38	Subchunk2ID	4	
little	40	Subchunk2 Size	4	
little	44	data	Subchunk2 Size	The "data" sub-chunk Indicates the size of the sound information and contains the raw sound data

<https://ccrma.stanford.edu/courses/422/projects/WaveFormat/>

Beispiel:

`/home/proj/mi_dm/110-220-440-880.wav`

WAVE-Format:

<http://www.sonicspot.com/guide/wavefiles.html>

<https://ccrma.stanford.edu/courses/422/projects/WaveFormat/>

The Canonical WAVE file format

WAVE

endian	File offset (bytes)	Field name	Field Size (bytes)	
big	0	ChunkID	4	The "RIFF" chunk descriptor
little	4	ChunkSize	4	
big	8	Format	4	
big	12	Subchunk1ID	4	
little	16	Subchunk1 Size	4	The Format of concern here is "WAVE", which requires two sub-chunks: "fmt" and "data"
little	20	Audio Format	2	
little	22	NumChannels	2	
little	24	SampleRate	4	
little	28	ByteRate	4	
little	32	BlockAlign	2	
little	34	BitsPerSample	2	
big	38	Subchunk2ID	4	
little	40	Subchunk2 Size	4	The "fmt" sub-chunk
little	44	data	Subchunk2 Size	
				describes the format of the sound information in the data sub-chunk
				The "data" sub-chunk
				Indicates the size of the sound information and contains the raw sound data

```

0000  52 49 46 46  RIFF
0004  1c 30 14 00  .O..
0008  57 41 56 45  WAVE
000c  66 6d 74 20  fmt
0010  10 00 00 00  ....
0014  01 00 01 00  ....
0018  44 ac 00 00  D-..
001c  44 ac 00 00  D-..
0020  01 00 08 00  ....
0024  64 61 74 61  data
0028  f8 2f 14 00  ø/..
002c  80 88 90 97  ....
0030  9f a7 af b6  .S~¶
0034  bd c4 cb d1  %AEN
0038  d7 dd e2 e7  xYâç
    
```

```

00024 64 61 da
00026 74 61 ta
00028 80 a9 .@
0002a 03 00 ..
0002c 80 7f ..
0002e 95 95 ...
00030 a8 a8 ...
00032 b7 b7 ..
00034 be be %%
00036 bf bf %
00038 b8 b8 %
0003a aa aa %
0003c 97 97 ..
0003e 82 82 ..
00040 6c 6c ll
00042 58 58 XX
00044 49 49 II
00046 41 41 AA
00048 40 40 @@
0004a 46 46 FF
0004c 54 54 TT
0004e 66 66 ff
00050 7b 7b {{
00052 91 91 ''
00054 a5 a5 %
00056 b4 b4 ''
00058 bd bd %
0005a bf bf %
0005c b9 b9 ll
0005e ad ad --
00060 9b 9b ..
00062 86 86 ..
00064 70 70 pp
00066 5c 5c \

```

WAVE

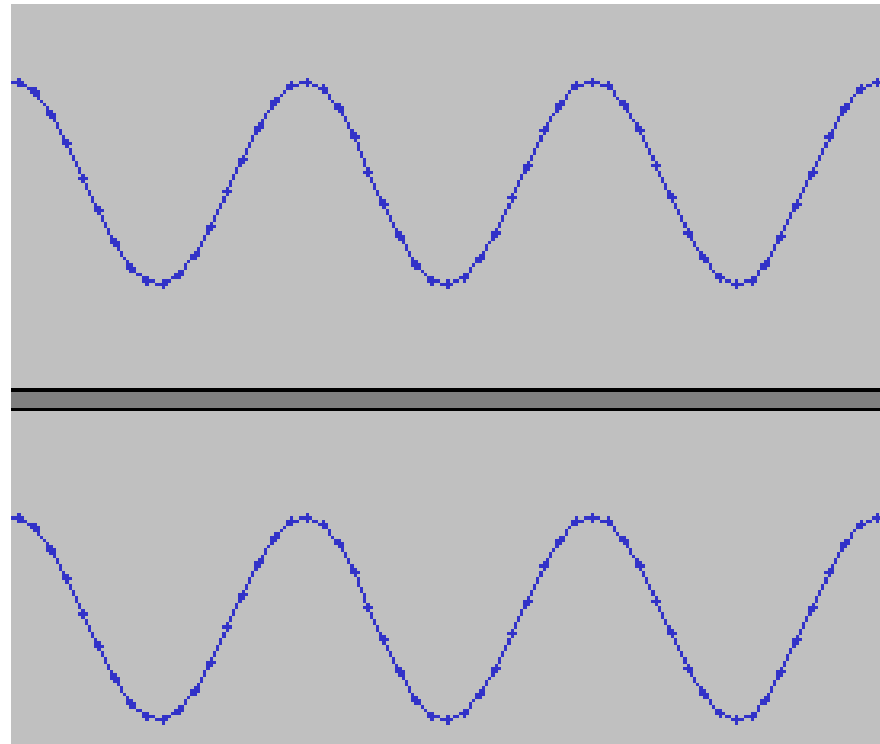

8-Bit Stereo

Interleaving

Die beiden Stereospuren werden abwechselnd in der Datei abgelegt